



Unified Communication Solutions



Amber Technology is a leading distributor of audio-visual brands for all types of installations in Australia and New Zealand. We offer a comprehensive selection of products to suit installation projects from large-scale commercial projects, live performance venues, education facilities, houses of worship, retail and hospitality, to cutting-edge residential projects.



At Amber Technology we also provide support to allow you to focus on what matters most. The Technical Sales and Support (TSS) Team at Amber specialises in commercial installation pre-sale system design, providing technical advice during the installation phase, and top quality ongoing post-sales support.

CONTENTS

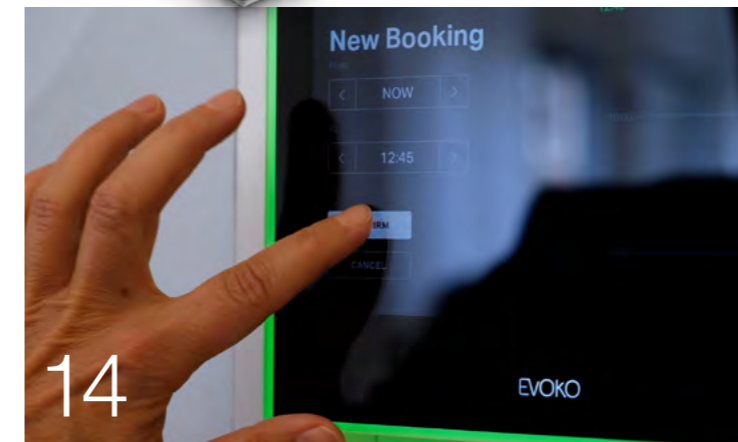

AUDIO

INPUT



PROCESSING



OUTPUT



VISUAL

INPUT

PROCESSING

OUTPUT





CONFERENCE CAMERAS

CAM130



The CAM130 is an affordable, professional grade USB conference camera optimised to deliver a next generation video communication experience. It is compatible with all of your favourite applications, connecting to virtually any desktop or laptop, via a single USB cable.

Product (Amber) SKU: AF-CAM130
Product (Manf.) SKU: CAM130

CAM520 PRO2



The CAM520Pro is equipped with a high-class 18X total zoom that displays every detail in crystal-clear quality. Also, on-trend technology such as AVer SmartFrame, Sony True WDR, and IP video streaming provide enterprises with a professional meeting experience.

Product (Amber) SKU: AF-CAM520PRO2
Product (Manf.) SKU: CAM520PRO2

CAM550



The CAM550 is equipped with next generation dual-lens technology that displays every detail in crystal-clear quality and provides enhanced dynamic tracking capabilities. Also, on-trend technology such as AVer Smart Gallery, SmartFrame, Sony True WDR, and IP video streaming provide enterprises with a professional meeting experience.

Product (Amber) SKU: AF-CAM550
Product (Manf.) SKU: CAM550

VB130



The All-in-One VB130 is equipped with the latest Intelligent Lighting so you can appear energetic and professional in any environment. Also, AVer's Audio Fence, beamforming technology, and audio tracking precisely pick up voices. There's even auto framing to fit every participant onscreen in seconds. Activate a brighter and better video conferencing experience with the VB130.

Product (Amber) SKU: AF-VB130
Product (Manf.) SKU: VB130

VB342 PRO



The VB342 Pro's high quality 4K PTZ camera delivers unprecedentedly vivid images and clear details. Intelligent AVer AI features come together to create a crystal-clear AI powered meeting experience. AVer's Smart Gallery, SmartFrame, Audio Fence, Sony True WDR, and Audio I/O for Hearing Augmentation provide enterprises with the premium professional meeting experience.

Product (Amber) SKU: AF-VB342PRO
Product (Manf.) SKU: VB342PRO

VC520 PRO TEAMS



The VC520 Pro is equipped with a 12X optical zoom and daisy-chain speakerphone that deliver a lifelike audiovisual experience. With 1080p HD quality, Sony True WDR, and IP-based management features, the VC520 Pro is the professional conferencing system your enterprise needs.

Product (Amber) SKU: AF-VC520PROTEAMS
Product (Manf.) SKU: VC520PRO
(Teams Edition)



PTC300 V2 SERIES AI AUTO TRACKING CAMERAS

Broadcast, stream, and record—all with one camera! Equipped with optical zooms and advanced AI tracking technology, PTC300 V2 series Professional PTZ Cameras capture every detail of classrooms, auditoriums, meeting rooms, stages, and houses of worship.

Product (Amber) SKU: PTC300 V2 series
Product (Manf.) SKU: PTC310HWV2, PTC310UV2,
PTC320UNV2, PTC330UV2



MODEL	PTC310HWV2	PTC310UV2	PTC320UNV2	PTC330UV2
OUTPUT RESOLUTION	1080p	4K	4K	4K
EFFECTIVE PICTURE ELEMENTS	2 MP	8 MP	8 MP	8 MP
OPTICAL ZOOM	12X	12X	21X	30X
AI TRACKING	●	●	●	●
3G-SDI Port		●	●	●
HDMI Port	●	●	●	●
PoE+ Port	●	●	●	●
USB Port	●	●	●	●
NDI CAPABLE			●	
COLOUR	White	Black	Black	Black

PTC500+ AUTO TRACKING CAMERA

Create engaging video for streaming, sharing and recording during lectures, demonstrations, video conferences, speeches, and more with the AVer PTC500+ Professional Auto Tracking Camera. Boasting a powerful PTZ camera with 30X optical zoom and a secondary 120° FOV panoramic camera, the PTC500+ provides crystal-clear full HD 1080p video resolution.

Product (Amber) SKU: AF-PTC500+
Product (Manf.) SKU: PTC500+





USB CONFERENCE PHONE

Compact and portable, our range of USB conference phones allows you to turn any workspace into an instant conference room. Ensure clearer conversations and better collaboration – just plug in and talk!



Revolabs FLX™ UC 500

From desktop workspaces to conference rooms, the Revolabs FLX™ UC 500 sets the new audio standard for PC-based unified communications applications.

Combining superior technology for speakers, microphones, and audio processing, the FLX™ UC 500 improves all aspects of audio handling for your communication needs and easily gives the “Best in Class” audio performance changing the price / performance paradigm in this space.

USB + VOIP CONFERENCE PHONE

Bring people together and move your business forward with Yamaha's range of innovative conference phones. The Revolabs FLX UC 1500 and FLX UC 1000 conference phones are enterprise-ready and provide wideband frequency response for spectacular-sounding audio.



Revolabs FLX™ UC 1000

The Revolabs FLX™ UC 1000 combines a VoIP phone with USB conference calling so your team can collaborate using the best communication channel. With integrated SIP technology, the UC 1000 works in all major telephony environments, and connects to all market-leading IP PBX's, integrating easily with third party conferencing applications.



Revolabs FLX™ UC 1500

The Revolabs FLX™ UC 1500 provides the answer for the larger conference room by increasing the speakerphone capability of the FLX UC 1000 IP and USB Conference phone with two additional directional microphones.



FLEXIBLE USB CONFERENCE PHONE

Make your communications loud and clear with Yamaha USB conference phones. Achieve superior audio quality, setting new standards for signal-to-noise ratio and the supported frequency range. The innovative design and technology are impervious to GSM noise from other wireless devices.



Yamaha YVC-1000

An intuitive unified communications audio solution, the Yamaha YVC-1000 is a Bluetooth enabled conference phone system for medium to large conference spaces that call for flexible audio, web, or video conferencing. The YVC-1000 features separate microphone and speaker units that smoothly integrate audio and video for natural, comfortable remote communication.



Yamaha YVC-330

No need to crowd around the phone – The Yamaha YVC-330 is a portable conference phone that delivers ample sound to fill huddle rooms and small conference spaces.



Yamaha YVC-200

Take calls anywhere with this personal speakerphone, designed to offer professional-quality audio while connected to your laptop, phone or tablet. With a headphone plug for private listening and a rechargeable battery for complete portability for up to 10 hours, it's perfect for open workspaces, huddle rooms, home offices, and travel.



WyreStorm APOLLO SERIES



APO-100 Plug and play conference speakerphone

The APO-100-UC is the entry level solution in the Apollo series of unified communication products. Designed for small meeting rooms and huddle spaces. Simply connect the included USB cable to any laptop and instantly have access to a premium conference speakerphone, no drivers or software required. The APO-100 also allows video passthrough via USB. Use the capacitive touch buttons on the top of the speakerphone to control volume, mute the microphone and even mute the video from your laptop, tablet, or smart phone.

Compatible with Microsoft Teams, Zoom, Skype, BlueJeans, Cisco WebEx, and other major conference platforms.

Product (Amber) SKU: WY-APO100UC | Product (Manf.) SKU: APO-100-UC

APO-210 Apollo WY-APO200UC / Apollo WY-APO210UC Presentation switcher and speakerphone in one

The Apollo 210 along with the Apollo 200 are unified communication devices that combine a speakerphone and presentation switcher into one unique and flexible device. Boasting a broad range of connectivity options including support for wireless casting the Apollo 200/210 is ideal for all meeting and common spaces. Integration of USB 3.0 allows easy connection of peripheral devices such as PTZ cameras.

The 210 also adds class C HDBaseT output to support dual-screen meeting spaces.

Compatible with Microsoft Teams, Zoom, Skype, BlueJeans, Cisco WebEx, and other major conference platforms.

Product (Amber) SKU: WY-APO210UC | Product (Manf.) SKU: APO-210-UC



APO-VX20 Video Bar

Introducing the brand-new Apollo VX20! Audio Fidelity and Video Clarity for the Hybrid Workspace with the All-in-One Multi Conferencing Device.

Apollo VX20 integrates a 4K wide-angle AI camera, video switcher, speakerphone, and dual 8W stereo speakers into one device. BYOD and share content with wireless casting from any Airplay and Miracast capable devices. Clear, focused, and auto-framed video capture by the integrated AI Tracking Camera.

For further audio reach, WyreStorm has released the add-on omni 360° APO-COM-MIC USB microphone for larger meeting spaces. Cascade up to 3 mics and ensure full coverage for the largest rooms. To complete the conference setup, the APO-DG1 USB-C dongle begins sharing your desktop with just a tap of a button. Confusing and complex connections are things of the past.

APO-VX20
Product (Amber): WY-APOVX20UC
Product (Manf.): APO-VX20-UC



APO-DG1
Product (Amber): WY-APODG1
Product (Manf.): APO-DG1



APO-COM-MIC
Product (Amber): WY-APOCOMMIC
Product (Manf.): APO-COM-MIC

WyreStorm SYNERGY SERIES

SW-220-TX-W Presentation Switcher

The SW-220-TX-W is the perfect solution for today's huddle spaces and small meeting rooms. This switcher is equipped with the essential connectivity to have a successful meeting. USB-C and HDMI local inputs provide simple methods for sharing content to a display. In addition to the wired inputs, the SW-220-TX-W also supports native wireless casting via Airplay and Miracast so content can be shared easily from a tablet or smartphone. Connect a 4K camera or other highspeed USB devices to the USB 3.0 device ports and take advantage of the power and unification that is USB-C.

Product (Amber) SKU: WY-SW220TXW | Product (Manf.) SKU: SW-220-TX-W



SW-540-TX-W Presentation Switcher

A truly collaborative presentation switcher with AirPlay and Miracast wireless screen sharing and quad-view picture-in-picture processing.

With the latest edition to WyreStorm presentation switchers, versatility is key and a must for today's meeting spaces. The SW-540-TX-W packs a punch with features that include 2x HDMI, VGA, and USB-C local inputs along with support for wireless screen sharing on Apple, Android, and Windows devices. An integrated USB hub allows you to connect peripheral devices such as a speakerphone, camera, or a keyboard/mouse both locally and remotely over the HDBaseT output. Create a full solution by pairing the SW-540-TX-W with our HALO series speakerphones, FOCUS webcams or CAM-200-PTZ.

Product (Amber) SKU: WY-SW540TXW | Product (Manf.) SKU: SW-540-TX-W



OFFICE SERIES

HALO VX10 Video Bar

Hold a smooth and productive video conference with HALO VX10 video bar. It integrates a 4K wide-angle AI camera, dual powerful stereo speaker and a beamforming four-microphone array into one device, offering you extraordinary audio and video experience. With its outstanding functions and exquisite design, HALO VX10 is ideal for small meeting room, huddle room as well as home office.



Product (Amber) SKU: WY-HALOVX10
Product (Manf.) SKU: HALO VX10

HALO 30, 60 and 90

Compact yet powerful, the Halo series of speakerphones offer a premium conference call experience. Choose between three available models (30, 60 and 90), each equipped with unique features. All Halo models support acoustic echo cancellation, active background noise reduction and voice enhancement. With 4 built-in mics arranged in a 360° array, pick up all audio clearly, no matter where you're located. Halo 60 adds Bluetooth capability for connecting mobile devices and a built-in battery for taking it on the go! Halo 90 is a speakerphone and USB-C docking station in one package. Equipped with an HDMI output and two extra USB ports for connecting a keyboard, mouse or Focus webcam!

Product (Amber) SKU: WY-HALO30, WY-HALO60, WY-HALO90
Product (Manf.) SKU: HALO-30 HALO-60, HALO-90



HALO 90

FOCUS 210 Intelligent Webcam

Pair the Apollo range with our Focus 210 webcam to complete your UC room solution. 4K ultra HD AI webcam with 120° wide angle, auto-framing, presenter tracking, 8x digital zoom, dual AI noise-cancelling mics and App control, ideal for small and medium-sized meeting rooms.

Product (Amber) SKU: WY-FOCUS 210 | Product (Manf.) SKU: FOCUS 210



XILICA®

Solaro QR1

Solaro QR1 is a compact and versatile DSP that handles analog, USB and Dante™ networked audio with ease.

Deliver exceptional audio quality to every space with the ultra-small-footprint Solaro QR1, a PoE-powered digital signal processor with eight user-configured I/O card slots. This open-architecture product can be populated with all combinations of Solaro Series I/O card, offering capabilities including analog audio, USB (with volume/mute status sync), GPIO, relay control and AES/EBU digital audio. Additionally, Solaro QR1 connects to an installed network over standard CatX cable with in-built 4x4 Dante™ audio networking, for streamlined connection of ceiling microphones and other IP-based audio products. With license-activated HearClear™ acoustic echo cancellation and an integrated control engine capable of Lua scripting, Solaro QR1 is an ideal solution for individual conference rooms, classrooms and legislative spaces at an exceptional price-point.

Mounting easily under a table, behind a display or in a drop-ceiling, Solaro QR1's small size and included installation brackets enable exceptional audio quality to be deployed in rooms that previously couldn't accommodate a DSP. With its single Ethernet port for power and data, and a dedicated Dante™ networked audio port, Solaro QR1 caters to enterprise, education and government customers who demand physical separation of audio and their traditional installed CatX network. Designed around collaboration and conferencing, Solaro QR1 offers Microsoft Teams volume and mute status sync over HID (with XC-SUB) for a flawless user experience.

Product (Amber) SKU: XI-QR1-SOLARO
Product (Manf.) SKU: QR1-SOLARO



Solaro FR1

Solaro FR1 is a multi-purpose, scalable signal processor suited to most medium-to-large applications

Deliver premium collaboration experiences without the cost. Solaro FR1 is a 1U 16-card-slot DSP with modular I/O functionality that can evolve to meet your future requirements, while benefiting from the processing power to drive multiple rooms over an installed CatX network. Xilica's open-architecture digital signal processor can be populated with any combination of Solaro Series I/O card, offering capabilities including analog audio, USB (with volume/mute HID support), GPIO, relay control and AES/EBU digital audio. With the capability to grow as you need, Solaro FR1 is a multi-purpose, scalable signal processor suited to most medium-to-large applications including multi-room conferencing, education spaces, and mass communication. Dante™ model also available.

Product (Amber) SKU: XI-FR1-SOLARO
Product (Manf.) SKU: FR1-SOLARO

Dante™ model: Product (Amber) SKU: XI-FR1-SOLARO-D
Product (Manf.) SKU: FR1-SOLARO-D



WOLFVISION®

WIRELESS PRESENTATION AND COLLABORATION SYSTEMS



CYNAP PURE and CYNAP PURE MINI

BYOD wireless presentation made easy!

When you're looking for a wireless BYOD presentation solution for your organisation – look no further than Cynap Pure, the leading solution for meeting rooms, classrooms and huddle spaces everywhere.

Product (Amber) SKU: WO-CYNPURE & WO-CYNPUREMINI
Product (Manf.) SKU: CYNAP PURE & CYNAP PURE MINI

CYNAP PURE PRO

Outstanding wireless presentation and collaboration

All the benefits of Cynap Pure, plus some features from our larger Cynap systems. Ideal add-on to existing infrastructure, combining wireless screen mirroring with a range of popular collaboration tools. BYOD wireless screen sharing, Whiteboard and annotation, Zoom, MS Teams/WebRTC meetings, Document and media player.

Product (Amber) SKU: WO-CYNPUREPRO
Product (Manf.) SKU: CYNAP PURE PRO



CYNAP CORE PRO

Advanced collaboration and presentation solution

Cynap Core Pro is a wireless presentation, web conferencing, and collaboration system, featuring wireless BYOD screen sharing for all iOS, Android, Windows, macOS and Chrome OS devices, together with a comprehensive range of collaboration and web conferencing tools. BYOD screen sharing, Zoom/MS Teams/WebRTC meetings, vSolution MATRIX compatible, optional capture agent for Panopto and other video management platforms, Whiteboard and annotation.

Product (Amber) SKU: WO-CYNCOREPRO
Product (Manf.) SKU: CYNAP CORE PRO

<p>CYNAP PURE & PURE MINI BYOD wireless presentation made easy</p> <p>A compact BYOD wireless presentation solution, perfect for classrooms, meeting rooms, and huddle spaces of all sizes, where high quality, easy-to-use, wi-reless screen sharing onto a central shared screen is the primary focus.</p> <ul style="list-style-type: none"> BYOD screen sharing Touchback-function Enterprise level security Flexible network integration Room management APIs Peripheral device control Whiteboard & Annotation (CYNAP Pure only) 	VS	<p>CYNAP PURE PRO Outstanding wireless presentation and collaboration</p> <p>With all the functionality of Cynap Pure, plus some of the features of our larger Cynap systems, Cynap Pure Pro is an ideal add-on to existing infrastructure, providing high performance wireless screen mirroring, combined with a range of popular collaboration tools.</p> <ul style="list-style-type: none"> BYOD screen sharing Touchback-function Enterprise level security Flexible network integration Room management APIs Peripheral device control Audio/Video USB input Document and Media Player Zoom, WebRTC Meetings IP stream receive Integrated Web browser Whiteboard Annotation Microsoft 365 (incl. Teams meetings) Optional Feature Pack 	VS	<p>CYNAP CORE PRO Advanced collaboration and presentation solution</p> <p>Easy to use collaboration system, providing 'core essential' collaboration features. Advanced network integration options make it an ideal centrepiece for smaller installations, and it is also a key component of our MATRIX active learning classroom solution.</p> <ul style="list-style-type: none"> BYOD screen sharing Touchback-function Enterprise level security Advanced network options Room management APIs Peripheral device control Audio/Video USB input Document and Media Player Zoom, Teams WebRTC Meetings IP stream receive Integrated Web browser Whiteboard & Annotation Microsoft 365 1x HDMI input vSol. MATRIX compatible Lecture Capture 	VS	<p>CYNAP Centrepiece of the modern classroom</p> <p>A powerful all-in-one wireless presentation and collaboration system, featuring a media player, web-conferencing, recording and streaming, BYOD wireless screen sharing, and annotation functionality. Also the 'main station' of our MATRIX collaboration solution.</p> <ul style="list-style-type: none"> BYOD screen sharing Touchback-function Enterprise level security Advanced network options Room management APIs Peripheral device control Audio/Video USB input Document & Media Player Zoom, Teams WebRTC Meetings IP stream send/receive Integrated Web browser Whiteboard & Annotation Microsoft 365 2x HDMI input vSol. MATRIX main station Lecture Capture HD Video recording Web-casting
--	----	--	----	--	----	--



YAMAHA | ADECIA

"SOUND" ACCELERATES BUSINESS

With new and ever-changing communication requirements, one thing remains the same: the need for high-quality, worry-free audio for collaboration. ADECIA helps organisations overcome challenges with implementation, configuration and room acoustics by providing all components required for a successful installation - designed to work seamlessly together to reduce set up time, costs and complexities.

RM-CG Ceiling Array Microphone



Available in black or white.

Multi-beam Tracking is a signal processing technology that can track multiple speaking participants by combining the use of beamforming technology to form directivity with multiple microphone elements to pick up sound. With multiple beams, each beam tracks different speakers' voices when multiple speakers are present.

RM-CR Remote Conference Processor



The heart of the ADECIA solutions, providing all the connectivity and room audio processing. Capable of managing up to 2 RM-CG or 8 RM-TT, and 2 VXL1-16P, connected via PoE switch utilizing Dante™. Automatically recognises connected devices on the same network for audio routing and is equipped with Auto tuning, auto mixing, analog I/O, USB, SIP (VoIP) and Bluetooth.

RM-TT Tabletop Array Microphone



Available in black or white.

The RM-TT is equipped with Auto Voice Tracking (automatic speaker tracking function) in each microphone, allowing for flexible room layout and participant positioning. RM-CR automatically selects the closest microphone to the speaker to pick up sound, enabling a highly clear voice to the far end.

RM-W Microphone Series



Moving a microphone itself or moving things near it usually causes echoes in typical microphone system, resulting in interruptions and stress. As the RM-W is equipped with an excellent high-speed echo canceller that can instantly remove the echoes, you can experience a stress-free focused conversation.

1 ADAPTIVE ECHO CANCELLER

While other echo canceller's measure the room and set levels once, Yamaha's adaptive echo cancellation is constantly scanning the environment for changes to deliver an uninterrupted, echo-free audio stream.

2 NOISE REDUCTION

When constant noise like a projector fan or air conditioner system enters the communication space, Yamaha's Noise Reduction technology removes these components to clearly convey the presenter's audio to the far-end.

3 AUTO GAIN CONTROL

This sound technology automatically adjusts voice levels to deliver a consistent, optimal volume level to the far-end, no matter if some voices are louder vs. weaker or closer vs. further away from the microphone. This automatic feature enables everyone to hear or be heard at an ideal level.

4 DEREVERBERATION

Reverberation from an acoustically-poor environment can make it difficult to distinguish a clear voice signal. Dereverberation suppresses these reverb components to deliver a highly-intelligible output.

VXL Series P model Dante PoE Powered Speaker

The VXL1B-16P and VXL1W-16P support the "Dante" audio network, and use a slim line-array configuration, making them an easy fit perfectly for conference rooms (in the size range of 12m×10m) that demand vocal clarity while imposing numerous constraints on space, and require both functionality and a sense of design.

Product (Amber) SKU: RY-VXL1(B-16P/W-16P)
Product (Manf.) SKU: VXL1(B-16P/W-16P)

Available in black or white.



SWR2311P-10G Intelligent L2 Network Switch with PoE+



An intelligent L2 switch that has the optimal functions for Dante and can supply PoE to connected devices. Maximum 30W can be supplied from each PoE-compliant port (240W in total).

Product (Amber) SKU: RY-SWR2311P-10G
Product (Manf.) SKU: SWR2311P-10G

YAMAHA | ADECIA

Complete Coverage from Sound Input to Output

ADECIA helps organisations overcome challenges with implementation, configuration and room acoustics by providing all components required for a successful installation - designed to work seamlessly together to reduce set up time, costs and complexities.

Reduce Time, Spend and Complexities

Audio/control signals can be transmitted with one network cable using audio network standard, "Dante", solving troublesome wiring and installation problems.

Natural and Comfortable Conversation Experiences

Each microphone is equipped with various processing functions and when combining with Yamaha's original voice processing technology "HVAD", it provides a smooth and stress-free remote conference conversation experience. HVAD (Human Voice Activity Detection) is Yamaha's technology to distinguish human voice from background noises. HVAD captures human voices and suppresses background noises, delivering a clear signal to the far end no matter where you meet.

Best Audio in Shortest Time

System automatically detects all components and configures them to be optimised for the room environment, taking into consideration location of speakers and microphones, reverberation characteristics of the room, and echo behaviour. Setting up a room can be as easy as following the configurator through four steps of configuration.

Customisation Options to Fit Your Use Case

By offering a wide range of variations such as ceiling array microphones, and tabletop array microphones, ADECIA meets demands of different audio systems for each conference space and provides operations suitable for various environments.

Integration into All Audio Environments

Equipped with various interfaces such as USB, Bluetooth®, SIP, and analog audio input/output terminals, the system allows the flexibility to use for both web conference system and telephone line conferences. Supporting Windows, macOS, iOS and Android, as well as compliance with market leading UC applications, ADECIA gives you the flexibility to customise the solution to your specific needs.

ADECIA SYSTEM EXAMPLE

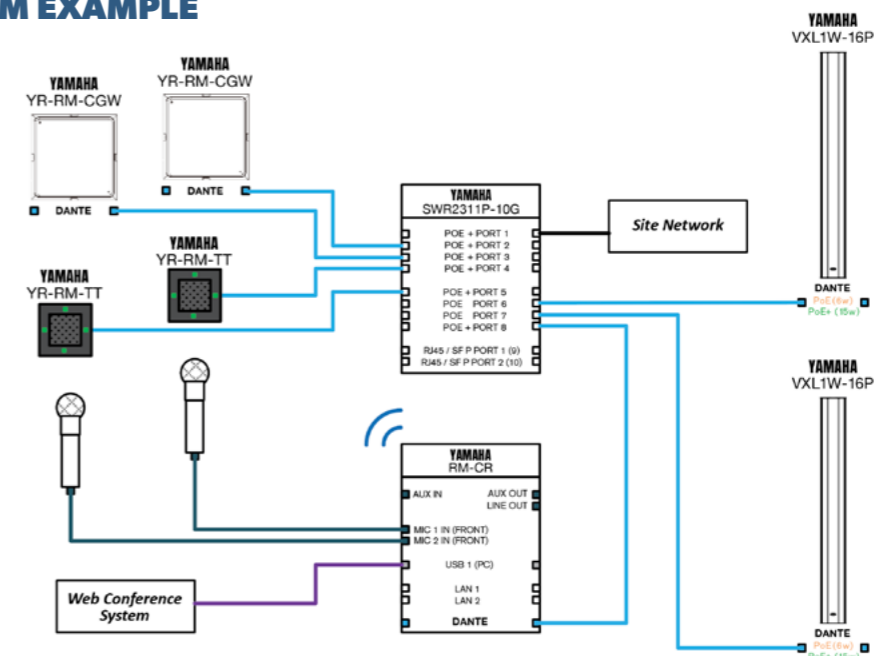

evoko™

CLEVER WORKPLACE SOLUTIONS

NASO Room Manager

The NASO Room Booking Solution that expands with desk booking and visitor management tools

A cloud hosted room device for easy interaction and room booking. This is the heart of the cloud suite, a room manager that covers everything from basic booking to an extensive range of functions. It's placed outside each bookable meeting room, conference room and other bookable areas.

The hosting licenses let you set up your system to a cloud hosted server. The hosting licences also provide essential functions such as booking, ability to edit bookings and check-in to meetings.

Product (Amber) SKU: EO-ENX1001
Product (Manf.) SKU: ENX1001

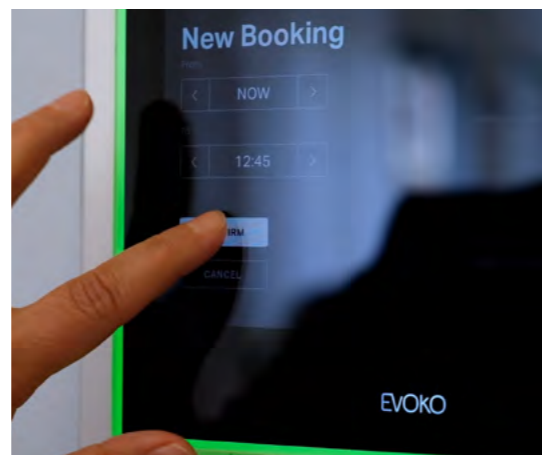

Evoko has developed award winning room bookers since 2009. The Evoko Naso takes the room booking experience to a new level of simplicity. At the same time, packages allow you to achieve complete workspace coordination including complete room services, coordinating all workspaces, personalised welcome messages and more. Also, desk bookings and visitor management.

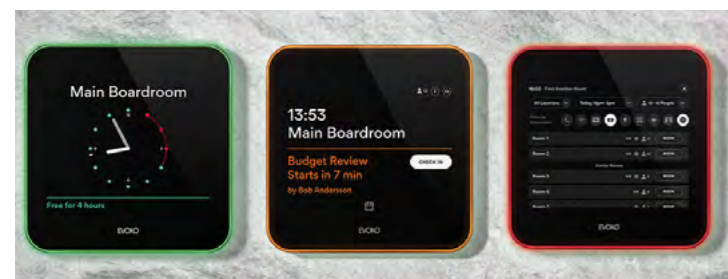

LISO Room Booking

The LISO room booking device with on-premises hosting

Whether you have security demands that don't allow cloud solutions or if you just want a more entry level solution for a one time cost, this is where you start. The heart of the solution is the LISO room manager, but it comes with analytics and extra functions that make your daily office operation run more smoothly.

It couldn't be easier. The self-hosted suite offers a complete room booking system.

The LISO room manager is a device for easy interaction and room booking. This is the heart of the suite, a room manager that brings all the features you need in a room booking device. It's placed outside each bookable meeting room, conference room and other bookable areas.

With this solution you will have full control over your self-hosted server installation and devices. Pay a one-time cost and receive a lifetime of product support and free updates.

Product (Amber) SKU: EO-ERM2001
Product (Manf.) SKU: ERM2001

newline

INTERACTIVE DISPLAYS, TOUCH SCREENS AND COLLABORATION DEVICES

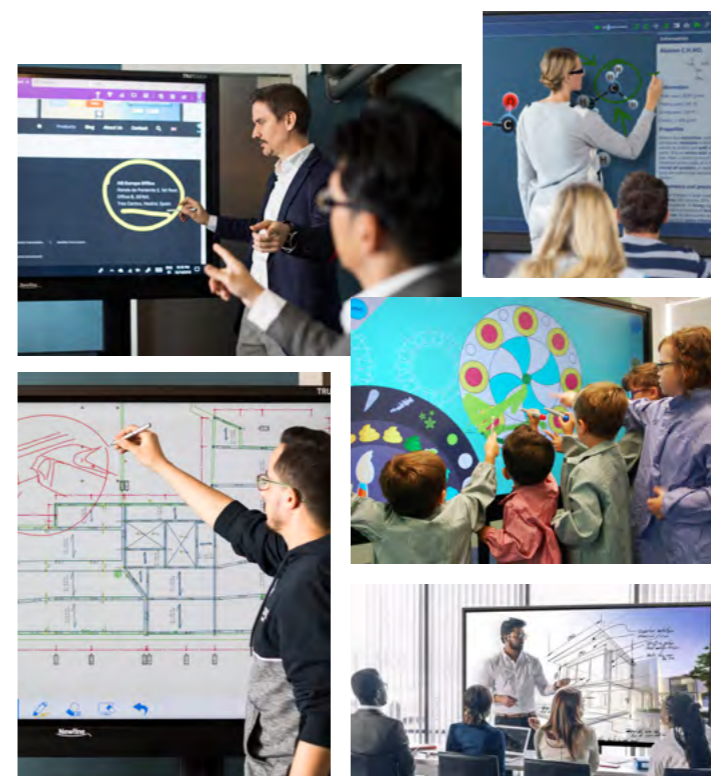

Newline Interactive

As one of the world's leaders in interactive touchscreen and unified communications/ collaboration devices, Newline Interactive is dedicated to creating solutions that are innovative and easy to use. Their display products are found in almost any style of collaborative environment around the world, such as boardrooms, huddle rooms and classrooms.

Newline has recently upgraded all of their Series with additional features and benefits for any type of interactive screen requirement.

Newline Interactive's products bring together:

- Unique hardware technologies
- Software applications that are developed in-house
- Industry-standard interfaces and connectivity
- Support for the world's leading communications and collaboration applications

Optoma

PROSCENE SERIES PROJECTORS

Optoma Projectors

Optoma ProScene Series Projectors deliver state-of-the-art products. Optoma is dedicated to delivering reliable, flexible, innovative solutions for multiple ProAV applications. Our solutions are optimised for long-life and ease of installation in auditoriums, art galleries, digital signage, and other large or outdoor venues. Our ProScene products let you confidently deliver ambitious solutions to your clients quickly and efficiently.

With laser phosphor technology the laser light source is a solid state lamp-less illumination technology that produces consistent high brightness up to 30,000 hours virtually maintenance free. Thanks to DLP™ technology, image quality and colour performance are second to none.



SPEAKERS AND AMPLIFIERS



AM QFC6CS



The QFC6CS QuickFit ceiling speaker uses a 6 inch, 2-way coaxial driver producing high SPL and intelligibility. The frameless grilles provide a modern sleek look sure to please end users, consultants and architects alike. If you require a black ceiling speaker it is as easy as changing the grille. A black grille for each model can be purchased separately as an accessory.

Product (Amber) SKU: AJ-QF6CS

AM QF60CS



The QF60CS premium coaxial ceiling speaker features a 6 inch, 2-way coaxial driver producing high SPL and detailed audio reproduction. The sealed back-can and front ported baffle provide improved bass response and isolation in the ceiling cavity. The frameless magnetic grilles allow easy removal of the grille for tapping changes and quick installation. A black grille is available as an option if needed.

Product (Amber) SKU: AJ-QF60CS

AM IS4120P + Optional Dante®



The ISP Series is Australian Monitor's premium offering of network controllable Class D power amplifiers. The IS4120P is a 4 x 120-watt amplifier which features ethernet control, embedded web browser user interface, DSP, ErP Standby Compliant and Dante® support via an expansion module. The ISP series give the AV contractor a reliable, feature rich amplifier for applications that demand the highest performance with ease of use.

Product (Amber) SKU: AJ-IS4120P
Product (Amber) SKU: AJ-DM4X4
Product (Amber) SKU: AJ-ANALOGUE4

AM HS120P



The HSP series are Australian Monitor's mid-range Class D power amplifiers.

The HS120P is a single channel 120-watt Class D power amplifier with both high and low impedance outputs. Optional free software allows access to a miniDSP providing, volume control, muting and a compressor/limiter.

Like all the HSP range it is USB and RS232 controllable.

Product (Amber) SKU: AJ-HS120P

SONANCE BEYOND SOUND

PS-C63RT



Designed to disappear. Discreet, modern bezel-less grille, and a smaller footprint than most 6.5" speakers. The PS-C63T offers great sensitivity, better frequency response and high-power handling while maintaining the architectural look of your space. Long throw bass drivers, high quality pivoting tweeter, full fidelity laminated core transformer. Better sounding, better looking, reliable and great value.

Product (Amber) SKU: SO-40131
Product (Manf.) SKU: 40131



YAMAHA VXL Series P model Dante® PoE Powered Speaker

The VXL1B-16P and VXL1W-16P support the "Dante®" audio network, and use a slim line-array configuration, making them an easy fit perfectly for conference rooms (in the size range of 12m x 10m) that demand vocal clarity while imposing numerous constraints on space, and require both functionality and a sense of design. Available in black or white.

Product (Amber) SKU: RY-VXL1(B-16P/W-16P)
Product (Manf.) SKU: VXL1(B-16P/W-16P)



ACCESSORIES AND ADD-ONS



GENERAL NETWORK INFRASTRUCTURE

Engineered with passion, best-in-class networking devices designed specifically for AV and Automation Systems. Routers, switches and wireless access points to suit every sized project, supporting industry leading remote monitoring and management platform, OvrC, for seamless IP System deployment.



OVR

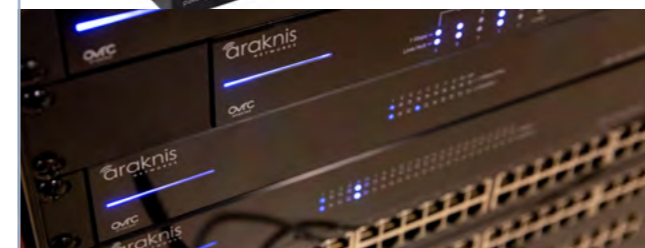

Grandview PROJECTION SCREENS

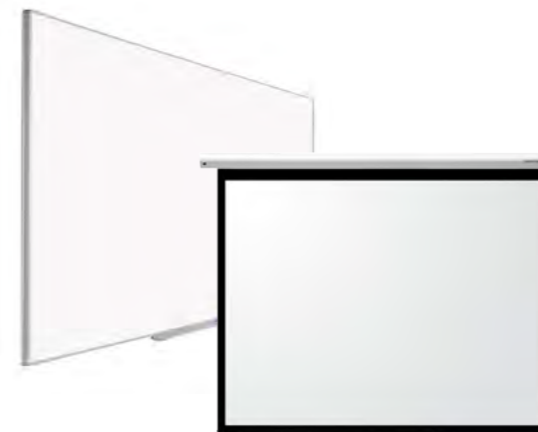

Grandview® offers a range of affordable projection screens and projector accessory solutions used in homes, schools, universities, workplaces, and venues across the country. Grandview's range showcases innovative engineering solutions, and great value-added features. From the patented SkyShow product, all in one Smart Screen or the simplicity of the Hideaway pre-installation box.



CLARITY ACOUSTIC ROOM KIT



Improve the acoustic experience in meeting spaces for both virtual and face to face meetings.

The Clarity Acoustic Room Kit comes with acoustic panels and mounting hardware to treat rooms up to 11m², for larger rooms simply add more kits. The panels are white and can be installed as is, or painted any colour to suit the décor of the room. The panels can also be printed; great for branding, design and aesthetics. The kit is designed to blend into the background while bringing your conversations and messages into focus.

For more complex installations, or a different look, ask us about the complete range of Primacoustic.

Product (Amber) SKU: RA-CLARITY-PT
Product (Manf.) SKU: Z900 0102 09



DIGITALINX ADAPTER RING CABLE ADAPTER SYSTEM

Don't be a loser - eliminate your customer's panic and expense when presentation adapters go missing or get lost! The patent-pending tensile aircraft strength ring and clamp locks on the cable going to your display keeping any adapter you may need is at your fingertips.

Make Liberty's breakthrough ring part of every install and feel the love from your customers!

Not only do you get a solid and reliable connection, but the adapters are guaranteed to stay locked so they won't get lost for the next presentation!



ACCESSORIES AND ADD-ONS



ENGINEERED WITH YOUR BUSINESS IN MIND

SurgeX helps you proactively mitigate, manage, and prevent power quality issues that negatively affect your business.

Downtime, service calls and phantom gear issues can be a time and money drain for your company. Providing superior protection and the ability to monitor and manage your AV system is imperative to the success of your company.

- Surges and spikes account for 63% of all power disturbances
- 80% of power disturbances originate from within buildings

The SurgeX suite of complete power protection and conditioning solutions gives your business the insurance needed to keep it up and running.

SurgeX offers the most advanced protection system in the market, bar none. The highest level of power protection and conditioning against damaging surges, spikes, over/under voltage, EMI/RFI noise, and electrical transients. Completely eliminates surge energy up to 6,000 volts.



USB3.1 HIGH SPEED ACTIVE OPTICAL CABLE

AVer Fibre USB extension cables provide all the flexibility for integrating USB connected devices over distance. Supporting up to USB3.1, this must have accessory is available in 10m, 20m or 30m and enables easy installation of any USB peripheral in your AV projects.



WALL PANELS



The Australian Monitor ZONEMIX solution offers optional wall panel accessories including 3 controller options, a Bluetooth receiver, and a mic/line level input. The WPBT Bluetooth receiver also allows name and PIN setting as well as pairing options. The 3 controller panels and the Bluetooth panel are setup in the ZONEMIX software.



TOUCH SCREEN CONTROLLER



With ColorMatch technology to showcase up to 16 million colours, a sleek edge-to-edge glass capacitive touch display, and an ultra-slim-profile, XTouch 80 is an eight-inch touch panel ideal for conferencing, education and legislative spaces demanding a high-definition, responsive control surface. Powered over standard CatX cable to IEEE 802.3af standard, XTouch 80 is simple and quick to install on a table with the optional XT80-TTS stand designed by StudioXTM, on-wall into a standard US dual-gang electrical box, and in both landscape and horizontal orientations.

Product (Amber) SKU: XI-XTOUCH80
Product (Manf.) SKU: XT80



SONIA

Unlike traditional speakers, Sonia is based entirely on CatX cable — enabling quick, easy installation with no messy termination or bulky copper wire. It enables everyone to deploy great audio in their space, without worrying about their setup. The Sonia Amp mounts directly onto Sonia C5 speaker for invisible, in-ceiling installation. The entire configuration eliminates in-room amplifier racks and hefty, expensive copper cable — and, Sonia C5 includes double-stepped, long travel mount ears for blind installation from below the ceiling. Sonia is designed for the modern collaboration space and includes a built-in network switch, enabling you to power an external ceiling microphone array direct from the device. That's just one CatX drop to the ceiling for your entire AV system. Running like a standard IT appliance, Sonia Amp enables centralised monitoring, management and control without the cost of individually-addressable speakers and being optimised for highly intelligible speech with voice match technology, the Sonia system will provide crystal clear audio for any sized room.

Product (Amber) SKU: XI-SONIA-AMP
Product (Amber) SKU: XI-SONIA-C5-P

BRIDGE THE GAP BETWEEN IT AND AV

Give your people the power to perform, with the flexibility of BYOM and the quality of an installed room system. Gio USB is a surface-mount USB-to-Dante endpoint, designed to bridge the gap between IT and AV by allowing connection of laptops and room PCs to a networked AV system. Supporting hybrid work and BYOM, Gio USB offers driverless compatibility with leading soft-codec platforms, including two-way volume and mute sync for Microsoft Teams, allowing control of room audio over HID. Easy to install with a single CatX cable and PoE to IEEE 802.3af, Gio USB mounts discreetly for flexible positioning near the room PC or conference table.

Product (Amber) SKU: XI-GIOUSB
Product (Manf.) SKU: GIOUSB



GIO BLUETOOTH CONNECTS PERSONAL BYOD TO THE IN-ROOM AV SYSTEM

Extend your networked AV system to BYOD devices, with the Gio Bluetooth® in-wall module. Leveraging the extended range and exceptional quality of Bluetooth 5.0 Class 2 technology, Gio Bluetooth connects personal peripherals such as smartphones, iPads and laptops to an in-room AV system with IT management functionality. Gio Bluetooth installs into a single-gang with just one CatX cable for both power and data, and offers installer-configurable device naming, PIN security and advanced pairing options.

Product (Amber) SKU: XI-GIOBT1
Product (Manf.) SKU: GIOBT1



HOLD. CHARGE. PROTECT. IPAD®



iPad has become the go-to device to control the app-driven connected world. By creating ways to hold, charge and protect it, iPad transforms into an epic dedicated controller.

Whether on the wall in fixed locations or removable, IPORT offers a range of charging and mounting systems so that you can experience iPad in a whole new way. Control, signage, check in, IPORT has you covered.



HIGH QUALITY HDMI TO USB 3.0 VIDEO ENCODER



Livestreaming is an essential medium for communicating with people around the world. With the UVC-01, it's never been easier to add high-quality livestreaming capabilities.

Just connect to the UVC-01 via HDMI, plug into your computer's USB 3.0 port, and start streaming to Facebook Live, YouTube, and other popular platforms. Offering plug-and-play operation in a rugged, pocket-size design, the UVC-01 is ready for action everywhere you go.

Product (Amber) SKU: UVC-01
Product (Manf.) SKU: RO-UVC01

ACCESSORIES AND ADD-ONS

SYSTEM EXAMPLES

HUDDLE/SMALL MEETING ROOM

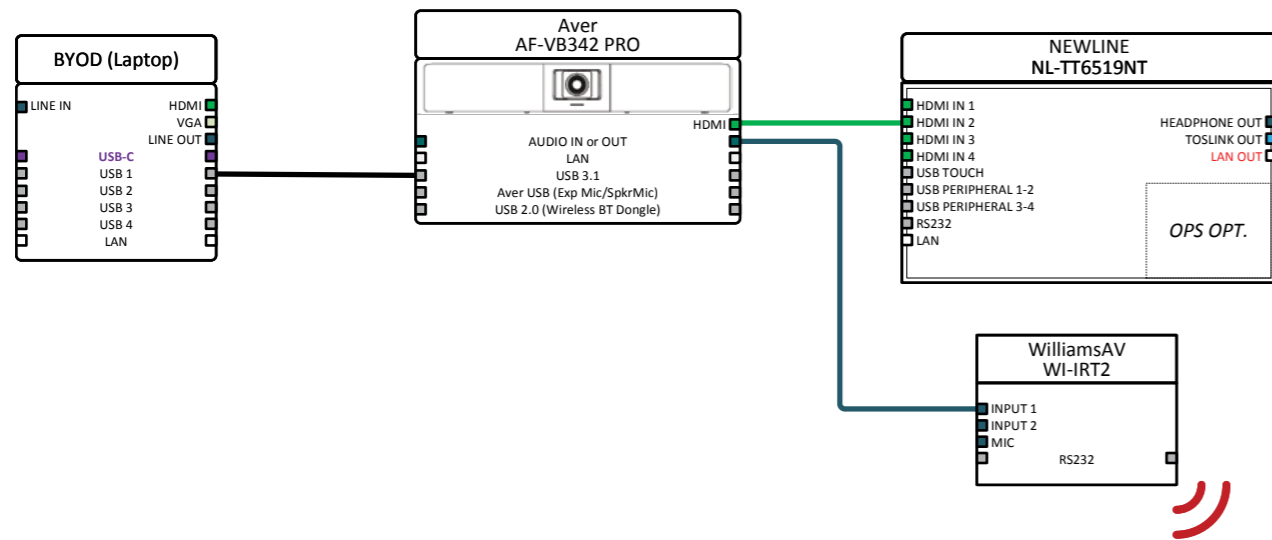

SYSTEM EXAMPLES

MED - LARGE MEETING ROOM WITH WIRELESS COLLABORATION

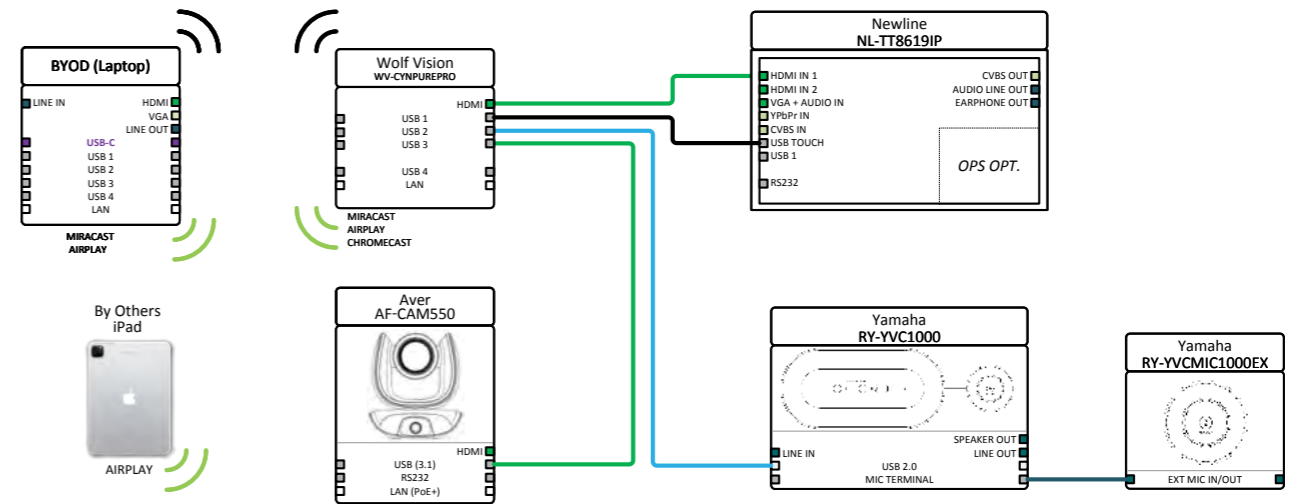

SMALL - MED MEETING SPACE

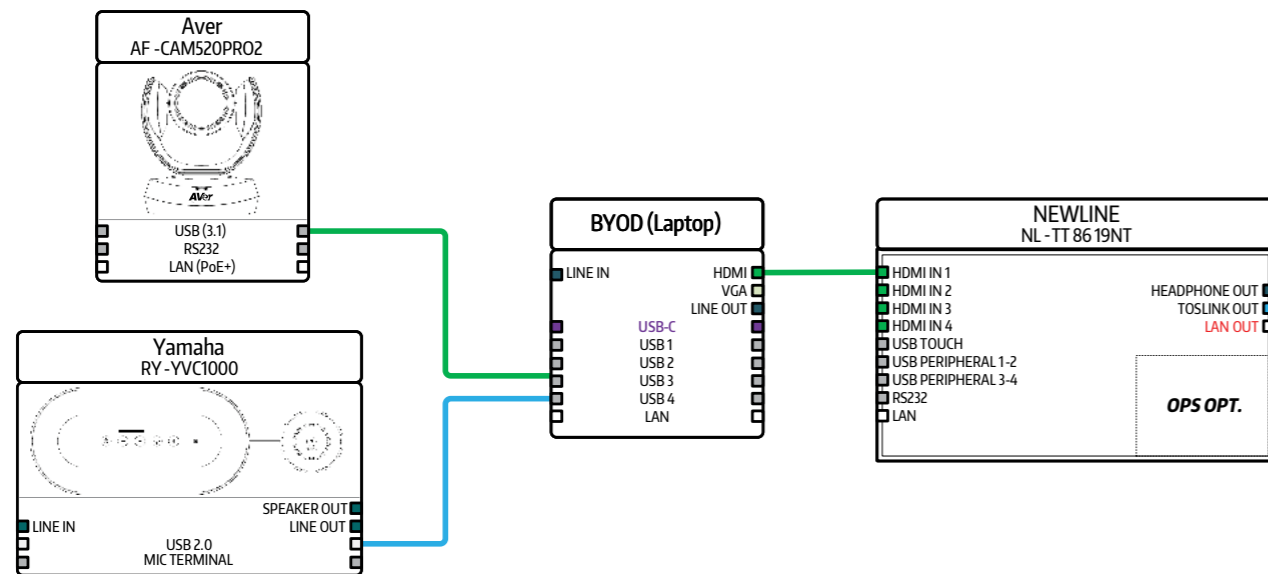

BOARDROOM OR MULTI-PURPOSE SPACE

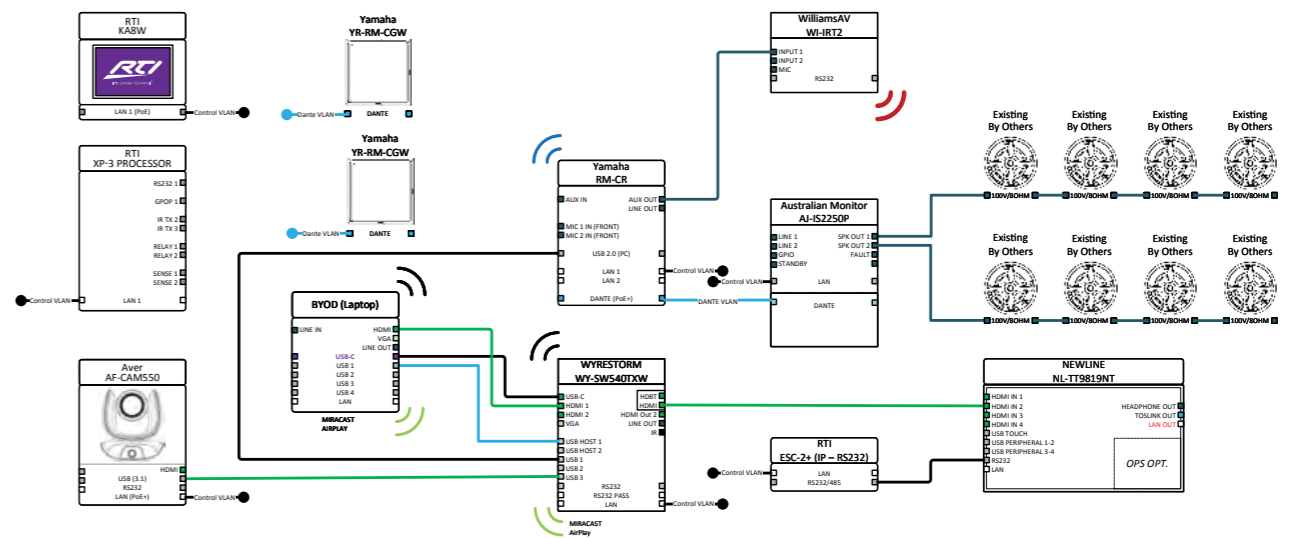

COMMERCIAL BRANDS

RESIDENTIAL BRANDS



IN ADMIRATION OF MUSIC



LIVE SOUND BRANDS





Amber Technology

Unit 1, 2 Daydream St
Warriewood NSW 2102
Phone: 02 9998 7600
Free Call: 1800 251 367

All Orders

sales@ambertech.com.au

Technical Sales and Support (TSS)

tss@ambertech.com.au

Service and Support

service@ambertech.com.au

Returns

returns@ambertech.com.au

Dealer Portal

Amber customers can create a login for our Self-service Dealer Portal using the form on website:

www.ambertech.com.au/apply

Dealer Portal Assistance

webshop@ambertech.com.au

Account Enquiries

ar@ambertech.com.au

Remittance Enquiries

remittance@ambertech.com.au

ambertech.com.au