

REVISIONS				
ECN	REV.	DESCRIPTION	DATE	APPROVED
	A	RELEASE FOR PRODUCTION	05-22-13	
14004	B	ADDED 3/8" THROUGH HOLE FOR WIRES	06-02-14	
20024	C	UPDATE DRAWING, BREAK OUT TOP PLATE	05-11-20	
21045	D	UPDATED TO PG11 GLAND	08-06-21	

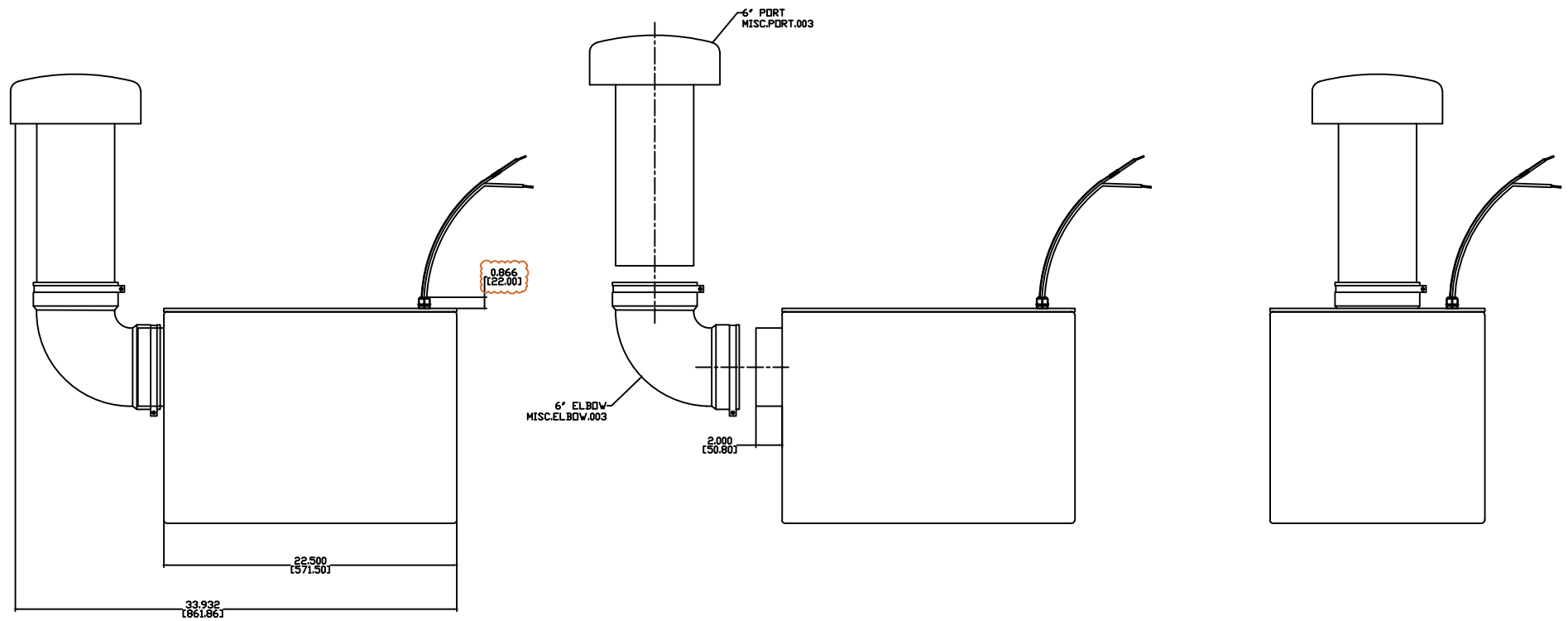

NOTES:

- 1: MATERIAL - 5052 ALUMINUM  
UNLESS OTHERWISE SPECIFIED
- 2: FINISH - STUDIO BLACK POWDER COAT  
UNLESS OTHERWISE SPECIFIED
- 3: MARINE GRADE
- 4: IMPEDANCE - 4 OHMS

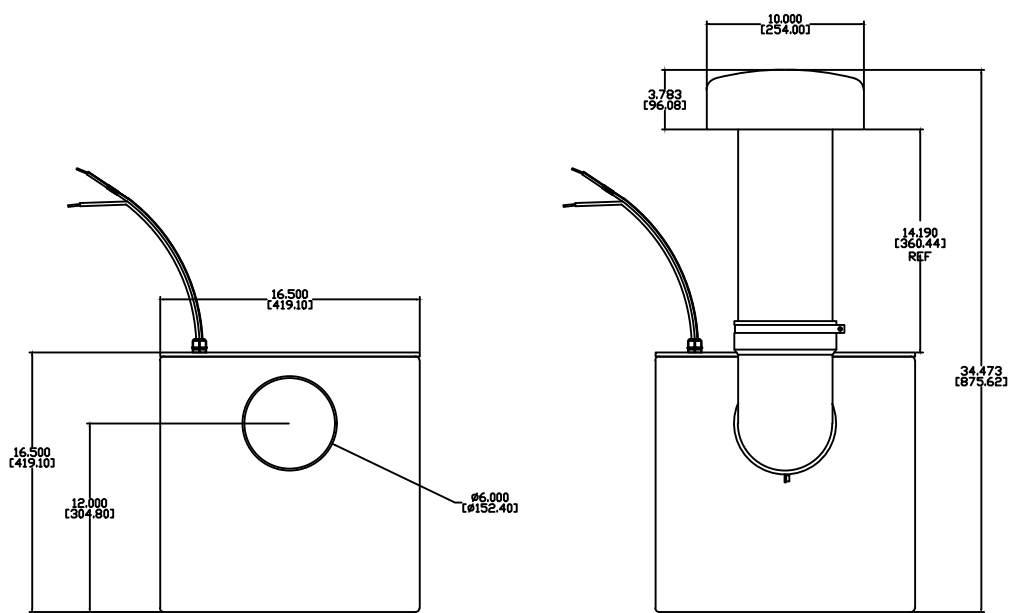
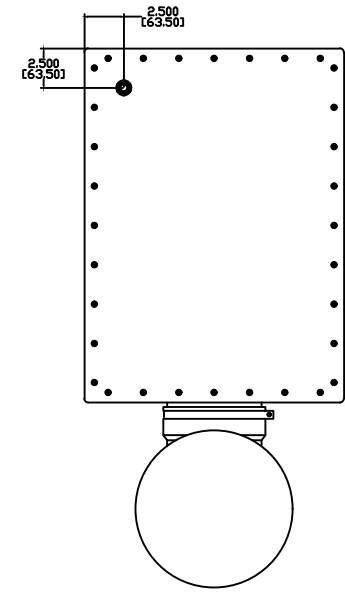
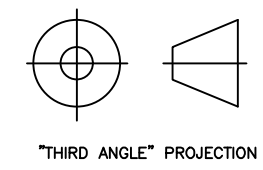

PROPRIETARY INFORMATION  
THE DESIGNS, INFORMATION, AND DATA CONTAINED HEREIN ARE PROPRIETARY AND ARE SUBMITTED IN CONFIDENCE, AND SHALL NOT BE DISCLOSED, USED OR DUPLICATED IN WHOLE OR IN PART, FOR ANY PURPOSES WHATSOEVER, WITHOUT THE PRIOR WRITTEN PERMISSION OF JAMES LOUDSPEAKER LLC, 2185 PARK PL, MINDEN, NV 89423. THIS LEGEND SHALL BE MARKED ON ANY REPRODUCTIONS HEREOF IN WHOLE OR IN PART. RECEIPT OF THIS DOCUMENT SHALL BE DEEMED TO BE AN ACCEPTANCE OF THE CONDITIONS SPECIFIED HEREIN.

**JAMES LOUDSPEAKER**  
**ST15**  
EXTERNAL DIMENSIONS  
P/N: -  
DWR #: 130522-A00  
REVISED BY: B. IJIMA  
DRAWN BY: M. PARK  
DATE: 05-22-13  
APPROVED:  
DRAFTING APPROVED:  
SCALE:  
TOLERANCES: ANG: ± = .5° FRACT. ± = 1/32  
DECIMALS: .XX ± = .01 .XXX ± = .005  
**REVISION: D**

SHEET 1 OF 4